

# PEW / PES

## Signal Light



LED



85dB at 1m  
(PEW-B only)

Electronic Sound 1  
(PEW-B only)

Ø82

IP55\*

NPN  
Open collector



\*PES: IP55 with rubber gasket SZ-210 (IP23 without SZ-210)  
\*PEW: IP54 (IP23 : Using the side wire exit)

## Dome shape LED Signal Light featuring enhanced visibility and maintenance-free operation.

- Newly Developed Triple-reflection System: For enhanced visibility and low power consumption.
- Flashing Cycles: 3 patterns —60/120/180 fpm, selectable by a switch.
- PEW-B type: Built-in audible alarm with adjustable volume up to 85dB at 1m.
- Maintenance-free: LED's power consumption is approx. half of incandescent bulb type (100V/200V AC).
- Installation: Indoors—upright, inverted, sideways; Outdoors—upright only.
- Dome: Superior weather resistant and light translucent acrylic resin.
- PEW: IP54 (IP23 : Using the side wire exit); PES: IP55 (with optional rubber gasket SZ-210, IP23 without SZ-210).
- CE Compliance: 24V AC/DC type ONLY.
- Available Colors: Red, Amber, Green, Blue.

### Available by Special Order

- Silver Color Body.
- IP65: PEW type only.
- UL type (E215660).

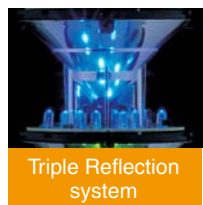

Triple Reflection system



Max. 85dB at 1m

## Dimensions (PEW, PES)

PEW

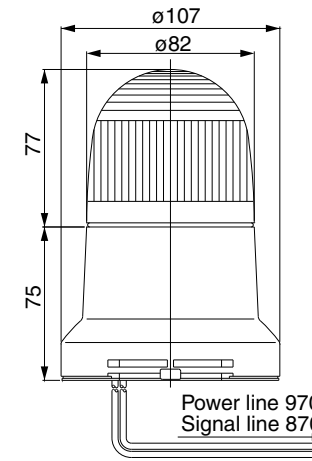

PES

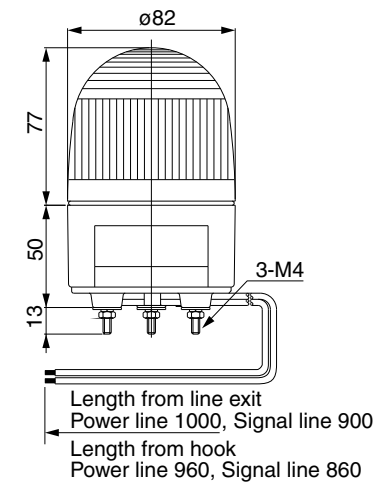

### Mounting Dimension

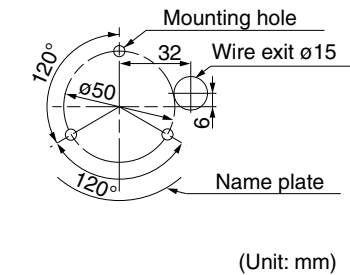
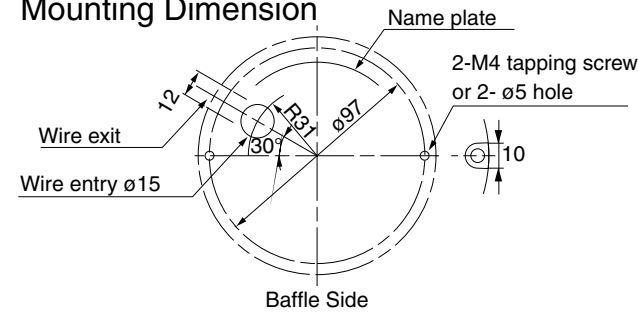

## Wiring Diagram

All models have the same wiring.

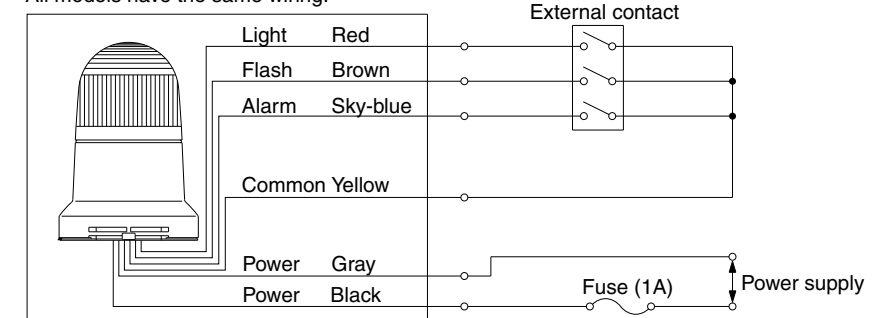

\* Skyblue line exists on buzzer type only.

### Transistor Operation Example

Transistor	NPN	Voltage proof	$V_c \geq 35V$
Current capacity	$I_c \geq 100mA$	Current leak	$I_L \leq 1mA$

## PEW/PES type

Model	Rated Voltage	Power Consumption	Flash Frequency	Mass
PEW-24	R/Y G/B	2.5W	Approx. 180 times/minute	0.32kg
PES-24	R/Y G/B			
PEW-24B	R/Y G/B	2.5W	Approx. 120 times/minute	0.34kg
PEW-100	R/Y G/B	5.8W		
PES-100	R/Y G/B	3.3W	Approx. 60 times/minute	0.43kg
PEW-100B	R/Y G/B	5.8W		
PEW-200	R/Y G/B	5.6W		0.52kg
PES-200	R/Y G/B			
PEW-200B	R/Y G/B	5.6W		0.54kg

## How to order

